

DESIGNER LINE DISPLAY REFRIGERATOR

Model: D3RNGDHD

Natural Refrigerant R-290 Model

Designer Line

3-Section Display Reach-In Refrigerator with Half Hinged Glass Doors

- D3RNGDHD** - Stainless steel front, aluminum end panels and interior
- D3RNSAGDHD** - Stainless steel exterior, aluminum interior
- D3RNSSGDHD** - Stainless steel exterior and interior



Options and Accessories

(upcharge and lead times may apply)

Stainless steel case back	Wine rack
Additional epoxy coated steel shelves	Casters
Chrome or stainless steel shelves	Full doors
Rehinging of door (consult factory)	Special electrical req. (consult factory)
Pan slide assemblies	Shallow depth (consult factory)
Solid doors (consult factory)	Pass-thru (consult factory)

Consult factory for other model configurations, options and accessories.

Continental
Refrigerator

Toll-Free: 800-523-7138
Phone: 215-244-1400
Fax: 215-244-9579

539 Dunksferry Road
Bensalem, PA 19020
www.continentalrefrigerator.com

Project Name:

Model Specified:

Location:

Item No:

Quantity:

AIA #:

SIS #:

Standard Model Features

REFRIGERATION SYSTEM

Self contained, performance rated "plug" refrigeration system

Natural, environmentally safe, high efficiency R-290 refrigerant¹

Refrigeration system is readily accessible on top of cabinet, separate from the "food zone"

Automatic, hot gas condensate evaporator

Expansion valve system

CABINET ARCHITECTURE

3" non-CFC polyurethane foam insulation

Triple-pane, tempered hinged glass doors

Chrome-plated handles

Cam action, lift-off hinges

Self-closing doors

Magnetic snap in door gaskets

Cylinder lock in each door

Heavy duty, epoxy coated steel shelves

Heavy-duty pilaster strips

Adjustable 6" stainless steel legs

MODEL FEATURES

LED interior lighting

Top and side air distribution ducts

Off-cycle defrost

Cabinet upper side panels and refrigeration "plug" system can be removed and reinstalled at job site

Electronic controller with digital display & hi-low alarm

¹ R-290 refrigerant meets all federal and state regulatory requirements.

APPROVAL:

Model Specifications

DIMENSIONAL DATA

Net Capacity (cubic feet)	72 (2039 cu l)
Width, Overall (inches)	78 (1981 mm)
Depth, Overall (inches) (including handles)	35 3/8 (899 mm)
Depth (inches) (less doors)	32 (813 mm)
Depth (inches) (doors open 90°)	55 1/2 (1410 mm)
Clear Door Width (inches)	19 3/8 (492 mm)
Clear Half Door Height (inches)	27 1/2 (699 mm)
Height, Overall (inches) (including 6" legs)	83 1/4 (2115 mm)
Number of Doors	6
Number of Shelves	12
Shelf Area (square feet)	61.2 (5.7 sq m)
Tray Slide Capacity (per half section)	11

REFRIGERANT DATA

Condensing Unit Size (H.P.)	1/2+
Capacity (BTU per hour)*	4010

ELECTRICAL DATA

Voltage (International)	115/60/1 (220/50/1)
Feed Wires (including ground)	3
Total Amps (International)	9.5 (6.2)
10 ft. Cord/Plug [attached] (International)	Yes (No)

SHIPPING DATA

Height - Crated (inches)	85 1/2 (2172 mm)
Width - Crated (inches)	90 (2286 mm)
Depth - Crated (inches)	42 (1067 mm)
Volume - Crated (cubic feet)	187 (5295 cu l)
Weight Std - Crated (pounds)	755 (342 kg)
Weight SS - Crated (pounds)	870 (394 kg)

* Rating @ +25°F evaporator, 90°F ambient
 Figures in parentheses reflect metric equivalents rounded to the nearest whole unit.



Equipped with one NEMA-5-15P Plug
 (varies by country)

Model Plan Views

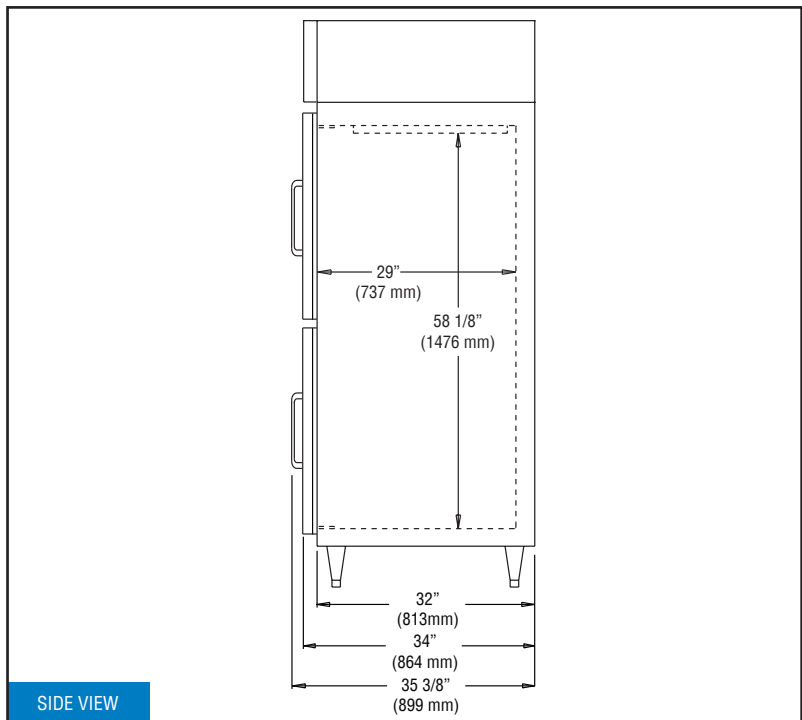
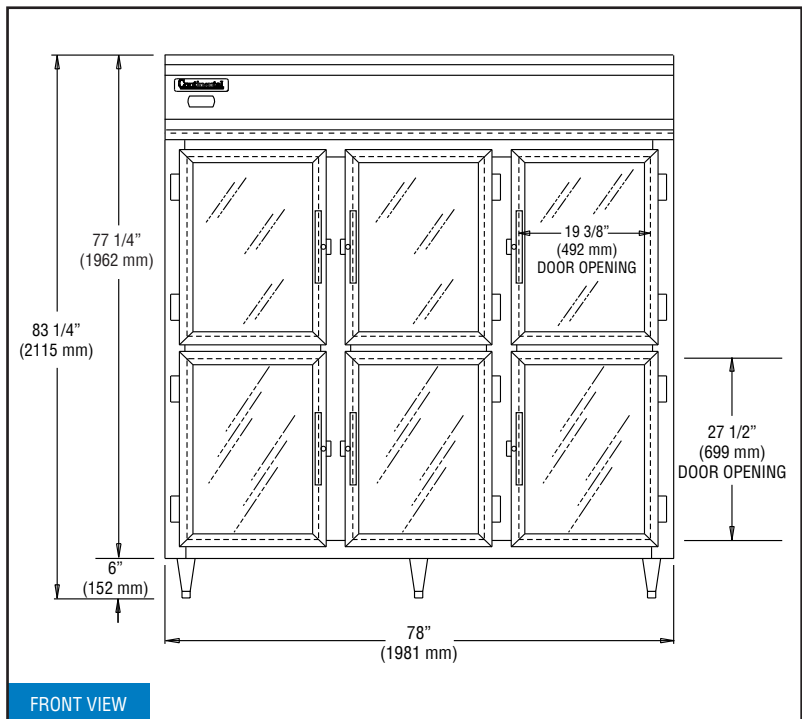

IMPORTANT NOTE: If the cabinet is located directly against a wall and/or under a low ceiling, a minimum clearance of 12" is required on top and 3" on sides and rear.



Toll-Free: 800-523-7138
 Phone: 215-244-1400
 Fax: 215-244-9579

539 Dunksferry Road
 Bensalem, PA 19020
www.continentalrefrigerator.com

Due to our continued efforts in developing innovative products, specifications subject to change without notice.

